

# NORWALL MANUFACTURING COMPANY

MANUFACTURERS OF

Automatic Air Valves, etc.

42 East 23d Street  
NEW YORK CITY, N. Y.

TELEPHONE 1322 GRAMERCY

138 Jackson Boulevard  
CHICAGO, ILL.

TELEPHONE 2571 HARRISON

## PRODUCTS.

The "ALLEN" AUTOMATIC AIR VALVE, the "NORWALL" AUTOMATIC AIR VALVE, the "NORWALL" AUTOMATIC AIR AND VACUUM VALVE, the "NORWALL" PACKLESS, QUICK OPENING, RADIATOR VALVE, and the "NORWALL" AIR LINE SYSTEM OF VACUUM STEAM HEATING.

## THE NORWALL AND ALLEN AUTOMATIC AIR VALVES.

The Norwall and Allen Automatic Air Valves are made entirely of metal. No perishable materials are used in their construction. The expansion force is simply air. The Norwall Automatic Air Valve is of the same general construction as the Allen Valve, but is larger and of heavier construction than the Allen. The principle of operation in both Valves is the same. The mechanical construction of both the Allen and Norwall Automatic Air Valves consists of a double shell, with the Radiator connection so placed as to form a well in the inner shell to receive and retain the water condensed from the steam as it passes into and through the Valve. A sealed metal float is placed in this well. Surrounding the inner shell is an air-tight chamber having a single outlet at the bottom, by means of which this air chamber is connected with the inner shell or float chamber. When steam reaches the Valve, the air in the air chamber is expanded by heat and the water is forced into the float chamber, thus carrying the float to its seat and closing the Valve against the emission of steam. When steam goes off, the air in the air chamber contracts and draws the water from the float chamber into the lower part of the air chamber. The float then drops from lack of sustaining fluid and thus opens the Valve. (See Figs. 1 and 2.)

## ADVANTAGES OF THE NORWALL AND ALLEN AUTOMATIC VALVES.

These Valves require no adjustment at any time, as there is no expansion post to buckle or get out of shape.

They are mechanically perfect in their construction. Dirt is the only element that will prevent their perfect operation, but in case of a Valve becoming clogged with dirt the bottom cap can be easily removed, which permits the thorough cleaning of the Valve. The Norwall and Allen Automatic Air Valves are the only Air Valves on the market that can be readily and easily cleaned without harming the Valve.

The Norwall and Allen Automatic Air Valves do not have to be adjusted; do not leak steam; do not leak water; do not do anything they ought not to do, but do automatically vent and heat every loop in every radiator when steam is on, and will keep them hot as long as steam is on. Specify them and be convinced.

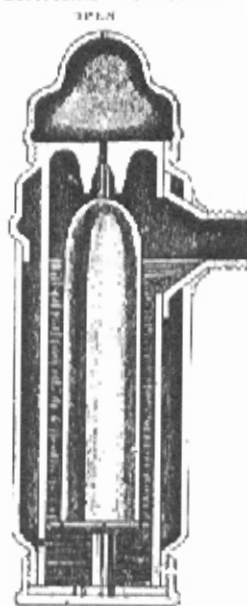

(Patent Applied For)  
Fig. 1. NORWALL AND  
ALLEN AIR VALVE OPEN

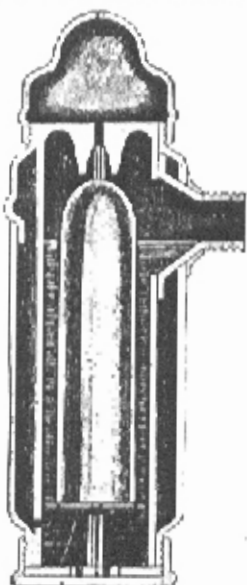

(Patent Applied For)  
Fig. 2. NORWALL AND  
ALLEN AIR VALVE  
CLOSED

## VACUUM HEATING.

The strong trend in modern low pressure steam heating is undoubtedly toward the combined pressure and vacuum system. It has long been a recognized fact by heating engineers that the ideal system of low pressure steam heating is one in which the apparatus is so constructed that the same can be operated either under pressure or under vacuum at the will of the operator. It is a commonly accepted fact that water boils and generates steam at 212 degrees, but it is not so generally known that the real boiling point of water when pressure is entirely removed from the same is 98 degrees Fahrenheit. The reason why water, ordinarily speaking, does not boil until it reaches a temperature of 212 degrees is, because the atmosphere or air which surrounds the earth's surface exerts a pressure at the sea level of 14.7 pounds per square inch. If we remove this pressure by exhausting the air from a vessel containing water and then seal this vessel, we can boil the water contained in the same at a temperature of 98 degrees, and this water will give off vapor or steam while boiling exactly the same as water does when boiling in an open vessel, under atmospheric pressure, at a temperature of 212 degrees. As we increase the pressure, we also increase or raise the temperature of water at its boiling point. For instance, water from which the pressure of the atmosphere has been entirely removed, will boil at 98 degrees. Water under a pressure of the atmosphere will not boil until it reaches a temperature of 212 degrees. Water under a pressure of ten pounds above the atmosphere, or in other words, the weight of the atmosphere, 14.7 pounds, plus 10 pounds, making a total of 24.7 pounds pressure on the water, will not boil until it reaches a temperature of 240 degrees. It is also a well known fact that it is possible to exhaust air from a vessel by filling that vessel with steam, then sealing the same and allowing the steam to condense. Steam occupies a space 1700 times greater than water from which it emanates, consequently when steam filling a sealed vessel is condensed to water, as the water occupies a space of 1700 times less than the steam, the space occupied by the steam will be left void or vacuum, provided the air is prevented from returning into this space. This phenomenon has long been a recognized fact by leading heating engineers, but the difficulty heretofore has been to find an economical device which would permit the air to be expelled from the system, automatically preventing the emission of steam when the apparatus was operated under pressure, and then automatically preventing the ingress of air to the apparatus when steam pressure was reduced below that of atmosphere. This difficulty has been entirely overcome by the invention of the Norwall Automatic Air and Vacuum Valve and the Norwall Air Line System of Vacuum Steam Heating.

## THE NORWALL AUTOMATIC AIR AND VACUUM VALVE.

The Norwall Automatic Air and Vacuum Valve is practically a Vacuum System in itself, when used in connection with an apparatus that is air-tight in all its joints and connections. All that is necessary to do is to screw on the Vacuum Valves in place of the ordinary Air Valves, and a complete system of Vacuum Steam Heating is installed.

The use of the Norwall Automatic Air and Vacuum Valve does not necessitate air lines or any mechanical appliances for exhausting the air. Pressure exhausts the air from the system through the Valve, and when pressure goes off the Valve automatically closes, preventing the ingress of air into the apparatus through the Valve.

## FEATURES OF CONSTRUCTION.

The venting portion of the Valve is the Norwall Automatic Valve, operating in the manner previously described, while the Vacuum attachment is a diaphragm chamber, with a diaphragm made of special bronze metal. The diaphragm chamber is directly connected to the radiator by means of the small pipe shown in the cut. A yoke surrounds the diaphragm chamber, being directly supported by the diaphragm. On the under side of the yoke is a Valve pin which seats itself in the upper part of

the Air Valve when the diaphragm is down, thus preventing air from passing into the Radiator through the Valve. When pressure of one-half pound reaches the Valve, the diaphragm is raised, which, in turn, unseats the upper Valve pin, thus allowing air to pass freely through the Valve.

The Norwall Automatic Air and Vacuum Valve is a mechanical device scientifically correct, and is designed for use in buildings heated by low pressure steam, especially in connection with residence work, stores and small apartments where the number of radiators in connection with any one plant is limited, or where the plant is practically in charge of one person.

When placed on every radiator and heating coil in such a building, the result is

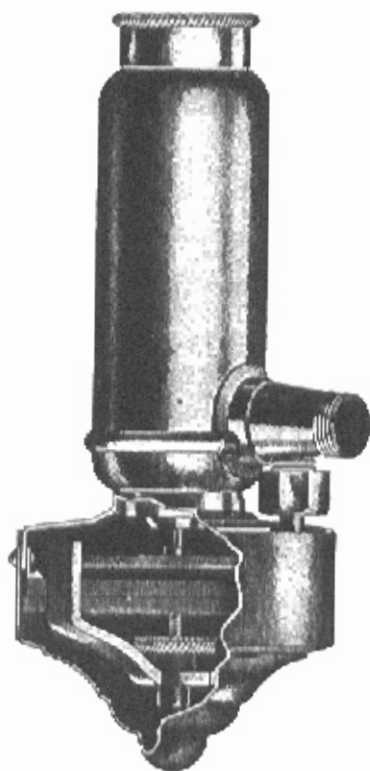

FIG. 3. NORWALL AIR AND VACUUM VALVE, ACTUAL SIZE  
(Pat. Feb. 9, 1904)

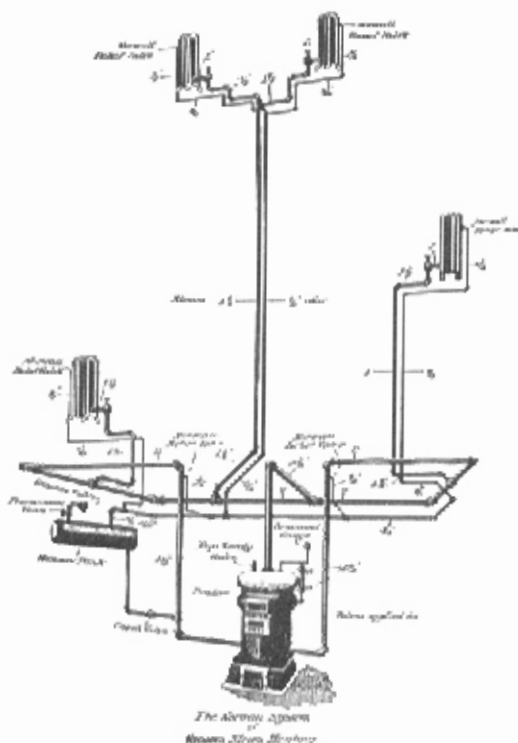

FIG. 4. A SINGLE-PIPE SYSTEM OF VACUUM STEAM HEATING

that the entire system can be operated either under pressure or under vacuum at will by the operator.

THE NORWALL  
AIR LINE SYSTEM  
OF VACUUM  
STEAM HEATING.

This system is designed for use on large buildings, such as apartment buildings, business blocks, etc., and contemplates the use of the Norwall Vacuum appliances in connection with the ordinary low pressure system of steam heating. The diagram illustrates a single pipe system (Fig. 4), but the Vacuum System is equally applicable to a double pipe system or any system of low pressure steam heating. In this system no automatic air valves are used on the Radiators. Each Radiator is fitted with a Relief Valve, which is open at all times when steam is on, permitting air, steam or water to pass freely through the same into the air lines, through which it is conducted to the Vacuum Tank in the basement. When the Radiator Steam Valve is closed, this Relief Valve automatically closes, thereby preventing the short circuit of steam back

into the Radiator through the Relief Valve. All air from the entire system is vented by pressure into the vacuum tank in the basement through the air lines, and from the tank through a large air valve either into the basement or it can be piped to a flue and thus vented directly to the outside atmosphere. When steam reaches the vacuum tank and seeks to find outlet through the thermostatic valve, this valve automatically closes, thus preventing the egress of steam from the tank.

#### ADVANTAGES OF NORWALL AIR LINE SYSTEM OF VACUUM STEAM HEATING.

A great advantage of the Norwall Air Line System of Vacuum Steam Heating in a building occupied by tenants, is the fact that the apparatus is at all times in direct control of the Engineer or Fireman. The Relief Valves being open as above described, at all times, insures a complete and rapid circulation of steam at atmospheric pressure throughout the entire system. It does away entirely with any liability of a leakage of water in the different apartments, as in case of any water passing through the Relief Valve from the Radiator, it simply finds its way back to the boiler through the air lines and vacuum tank. After the air has been expelled from the system and pressure ceases, the Vacuum Valve on the Vacuum Tank automatically closes and prevents the return of air to the tank and system, thus enabling the Engineer to operate the plant under pressure or vacuum according to the demands of the weather.

One great objection to the ordinary low pressure system is the fact that when the fires are banked for the night, or allowed to run low during a spell of mild weather, the Radiators soon begin to cool off, and in a very short time become stone cold, and the apartments in which they are placed become more or less chilly, according to the condition of the outside temperature.

By the use of the Norwall Automatic appliances for Vacuum Heating this condition is entirely changed. If the job is tight, the appliances will freely vent the Radiators of all air when pressure at the boiler registers one pound or over, automatically closing when steam reaches the Valves, and, when pressure goes off, by automatically preventing the ingress of air to the system, will keep the Radiators and coils in connection with the boiler hot for hours after pressure is off.

The economies to be derived from the operation of a combined pressure and vacuum system of ordinary low pressure steam heating are so self-evident, that it is apparent that no man who is using, or expects to use, low pressure steam heating would ever be content to continue to operate his plant simply as a low pressure steam heating apparatus, if he was fully advised of the advantages and economies to be derived by adding the Norwall Vacuum appliances to his apparatus. We, therefore, invite your careful consideration of the Norwall Manufacturing Company's systems of Vacuum Steam Heating.

#### THE NORWALL PACKLESS QUICK OPENING RADI- ATOR VALVE.

This is a packless valve, requiring no packing of any description to insure against the leakage of steam, water or air around the stem of the valve.

#### FEATURES OF CONSTRUCTION.

The sectional cut of the "NORWALL" Packless Radiator Valve (Fig. 6) illustrates the mechanical construction of the Valve. The body and Valve seat are similar to those used in the best grade of Radiator Valves. The upper Valve stem is stationary, with a socket on its lower end which conveys the turning motion to the stem of the Valve seat. The Valve seat stem is a screw, threaded in the valve bonnet, or nood, with a key on its upper end, and as it is turned by the upper Valve stem, rises into the socket in the upper Valve stem, which, as stated above, is stationary. The upper Valve stem has a flange near its lower end, and this flange rests on a turned round edge on the upper end of the bonnet, forming a ground ball-seated joint.

ADVANTAGES OF  
NORWALL PACK-  
LESS QUICK  
OPENING RADI-  
ATOR VALVE

The packless feature of this Valve is the ground ball-seated joint between the bonnet and the flange on the upper Valve stem. This joint being a ground joint is kept in close contact by means of pressure exerted by a steel spring incased in a cap, which is screwed on to the bonnet of the Valve from above. The spring exerts an elastic pressure on the flange, thus keeping the surfaces of the joint between the flange and the bonnet in firm and constant contact, making it not only steam and water proof, but air proof as well. The joint being between the steam chamber and the spring chamber prevents the steam from coming in contact with the spring, thus insuring it against damage by steam.

While the packed Valve causes more or less annoyance and expense when used in connection with the ordinary steam job, it is in Vacuum Steam Heating that its use causes the greatest trouble and expense. No matter how carefully the fitter packs the Valve stems, or what packing he uses, sooner or later the Valves begin to leak,

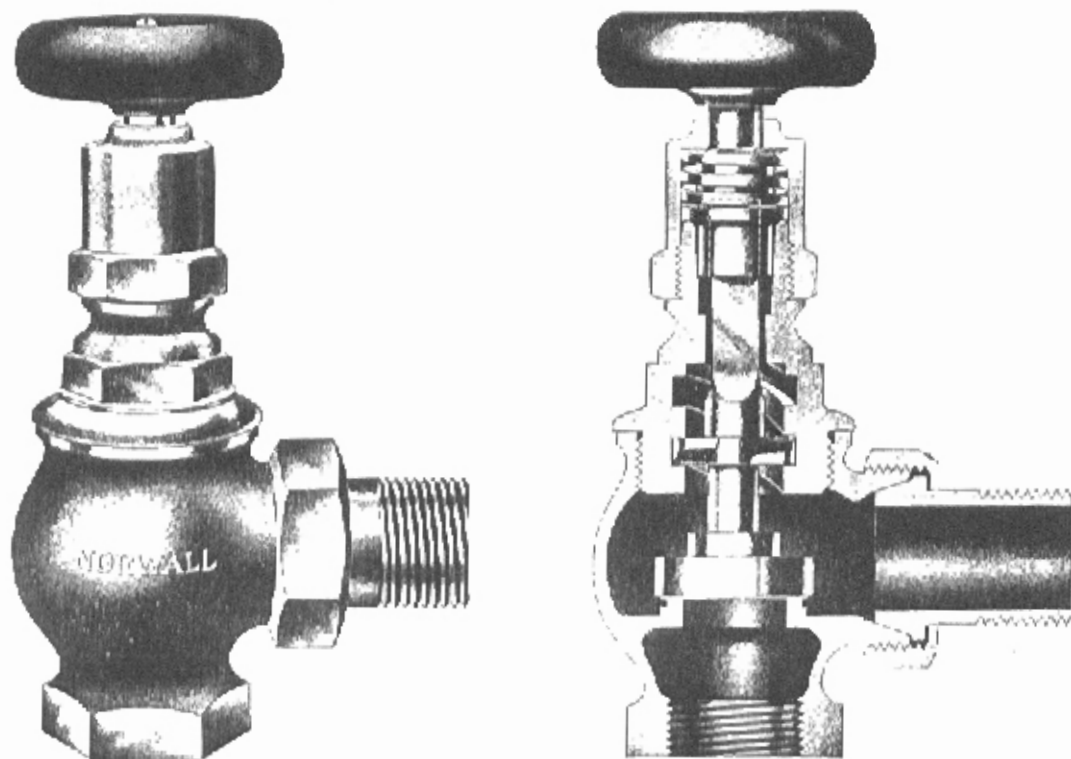

(Patent Applied For.)

FIGS. 5 AND 6 THE "NORWALL" PACKLESS QUICK OPENING RADIATOR VALVE

and the job as a Vacuum job is a failure until the leaky Valves are repacked. A Vacuum job may be perfect and absolutely tight in all its other joints, and yet if equipped with packed Radiator Valves it will soon begin to develop leaks through the Valve stems, thus making it impossible to hold Vacuum. All this trouble, annoyance and constant source of expense is entirely done away with by using the "Norwall Packless, Quick Opening Radiator Valve."

The Norwall Packless Radiator Valve will not only be steam, water and air tight at the start, but will remain tight, no matter how frequently it may be used or how long. Its use is an absolute insurance against the leakage of steam or water through the Valve when pressure is on, and on the boiler, and against the leakage of air into the Radiator when vacuum is desired. The Norwall Packless Radiator Valves are quick opening, requiring but three-quarter turn to open or close them.

SIZES AND  
DISCOUNTS.

The Valve is made in the usual sizes, both angle and corner, and discounts are based on same list as standard Valves.