

March 20, 1928.

1,663,271

A. KEHM

PIPE FITTING

Original Filed April 3, 1924

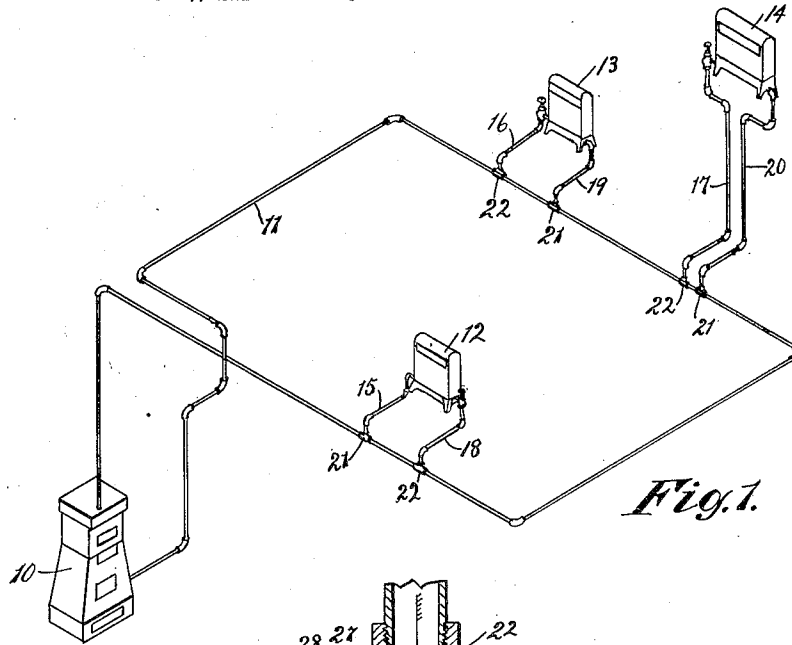

Fig. 1.

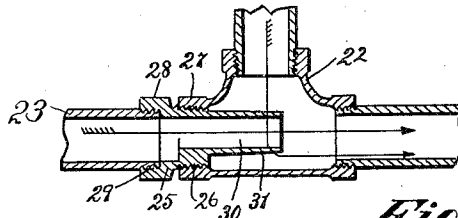

Fig. 3.

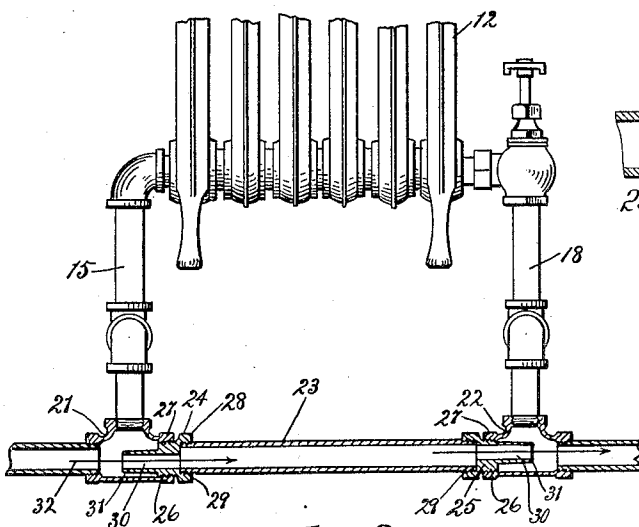

Fig. 2.

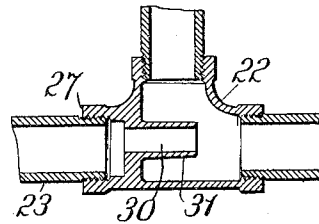

Fig. 4.

Inventor:

August Kehm

By Gillson, Mann & Coy,

Attys

UNITED STATES PATENT OFFICE.

AUGUST KEHM, OF CHICAGO, ILLINOIS.

PIPE FITTING.

Original application filed April 3, 1924, Serial No. 703,909. Divided and this application filed August 31, 1925. Serial No. 53,515.

This is a division of my application now pending, Serial No. 703,909, filed April 3, 1924, on hot water heating system.

The invention relates to pipe fitting and has for its principal objects to provide a connection that will facilitate the flow of water from a main to a lateral and from a lateral to a main and to provide a fitting that may be readily combined with conventional three-way joints to produce that result.

In a conventional hot water heating system where a supply riser and a return riser connect a main and a radiator it is necessary to space the joints between the respective risers and the main four to six feet apart in order to get the required flow through the radiator. This invention permits those joints to be spaced at any convenient distance.

Other objects and advantages of the invention will become apparent as the description is read in connection with the accompanying drawings, in which

Fig. 1 is a diagrammatical view of a single pipe hot water heating system,

Fig. 2 is a detail view illustrating the joints between the main and the risers,

Fig. 3 is an enlarged sectional view of a conventional T-joint equipped with a fitting according to this invention, and

Fig. 4 is a longitudinal sectional view of a one-piece fitting embodying the elements of a conventional T-joint and this invention.

Referring to Fig. 1, 10 indicates a boiler, 11 a main connected with the boiler at the top and the bottom; 12, 13 and 14 radiators connected with the main by supply risers 15, 16, and 17, and return risers 18, 19 and 20, respectively. The connections between the risers and the main are usually made by inserting conventional T-joints 21 and 22. This practice can be continued with the present invention by shortening the intermediate length of main 23 and inserting two fittings made according to this invention and illustrated in Fig. 2, at 24 and 25. These fittings include a threaded portion 26 adapted to thread into one of the opposed threaded sockets 27 of the conventional T. Adjacent to this threaded portion is an enlargement 28 equipped with a suitable wrench

seat. This enlargement is counter bored and threaded at 29 in substantial duplication of the sockets 27 and concentric therewith when assembled in the relation shown. The bore of the plug 30 beyond this counter bore is eccentric with respect to the counter bore and the threaded portion 26, and is prolonged by a tubular extension 31.

In the case of the supply riser the plug is set with its axis below the axis of the main and in the case of the return riser, the plug is set with its axis above the axis of the main. Water approaching from the right in Fig. 2 passes into the T 21, and meets the obstruction formed by the plug with the result that the water readily flows up the supply riser and into the radiator. The bore 30 of the plug is smaller than that of the main and permits a portion only of the water to pass on in the direction of the arrow 32. At the return riser the water passing through the intermediate section 23 of the main will be hotter than that returning from the riser to the main, and the tubular extension 31 will direct it along the upper side of the main while permitting the cooler water to follow its natural tendency to descend to the bottom of the main with less than normal resistance.

The fitting can be stocked as other fittings and readily assembled with conventional fittings for a great variety of purposes. The illustration here given for converting a conventional T into a special fitting for hot water heating systems is sufficient to show how the device is to be used in practice, and those skilled in the art will readily make other applications out of it.

It is not essential that the fitting 24 and 25 be separate from the T-joint and in some cases it is desirable to have them made in one piece. Such a construction is shown in Fig. 4 in which corresponding parts are indicated by the same reference numerals.

I claim as my invention:

1. A pipe fitting having opposed openings of the same size in substantial alignment and an intermediately disposed lateral opening directed transversely to the opposed openings, an obstruction between one of the opposed openings and the intermediate open-

ing, and a single eccentric tube carried by the obstruction and extending towards the other opposed opening.

2. A pipe fitting having opposed threaded
5 openings of the same size and a lateral opening between them, a hollow plug threaded into one of the opposed openings and including a single eccentric tubular portion

extending inwardly across the lateral opening, and an outer portion having an internally threaded bore of the same diameter as the bore in which the plug is threaded. 10

In testimony whereof I affix my signature.

AUGUST KEHM.