

B. R. DOODY.  
 LOW PRESSURE STEAM AND ANALOGOUS SYSTEM.  
 APPLICATION FILED JAN. 14, 1909.

930,650.

Patented Aug. 10, 1909.

2 SHEETS—SHEET 1.

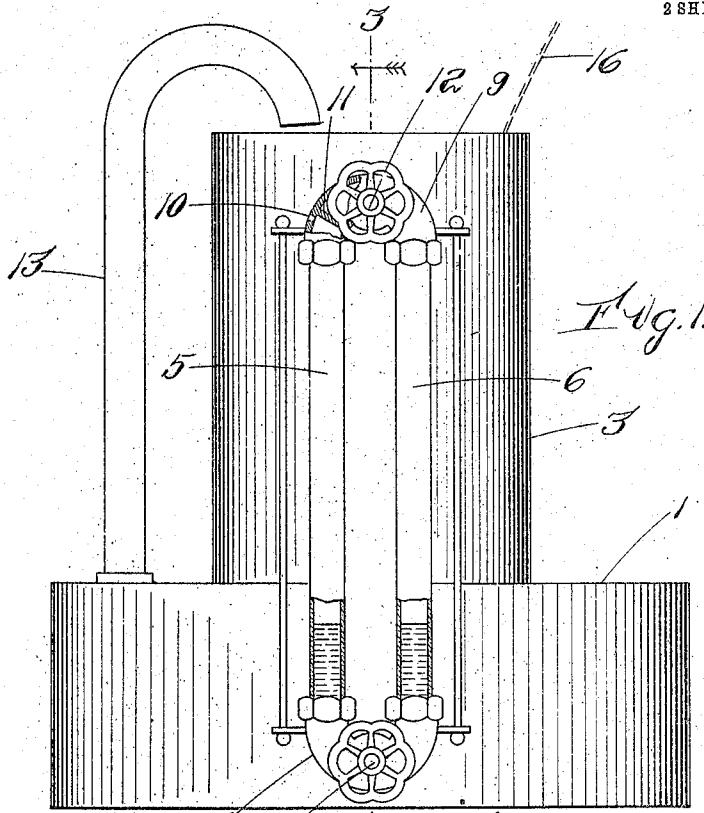

*Fig. 1.*

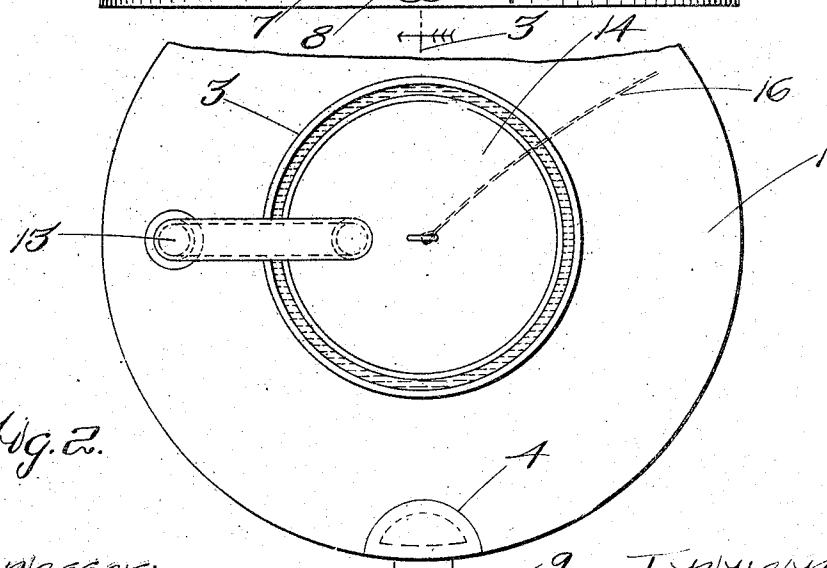

*Fig. 2.*

Witnesses:  
 John H. Parker  
 Alice E. Carr

Inventor:  
 Bartholomew R. Doody  
 by Macdonald, Culver, Copeland & Sibley  
 Attorneys.

B. R. DOODY.  
 LOW PRESSURE STEAM AND ANALOGOUS SYSTEM.  
 APPLICATION FILED JAN. 14, 1909.

930,650.

Patented Aug. 10, 1909.

2 SHEETS—SHEET 2.

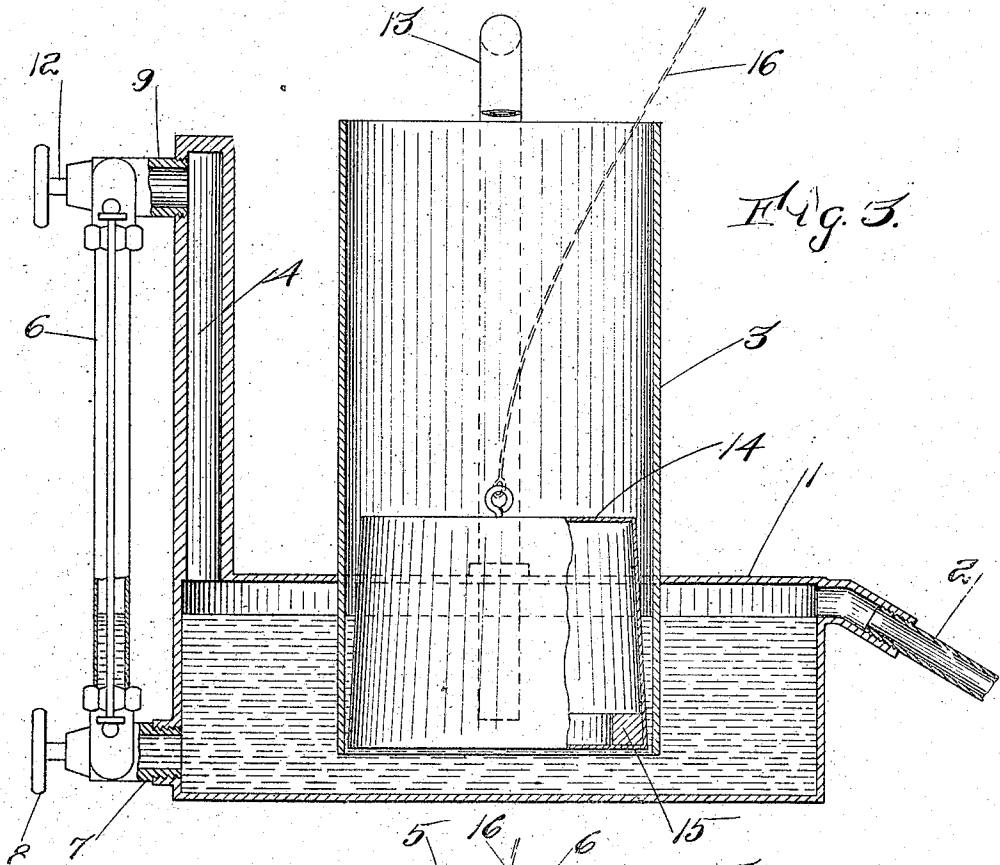

Fig. 3.

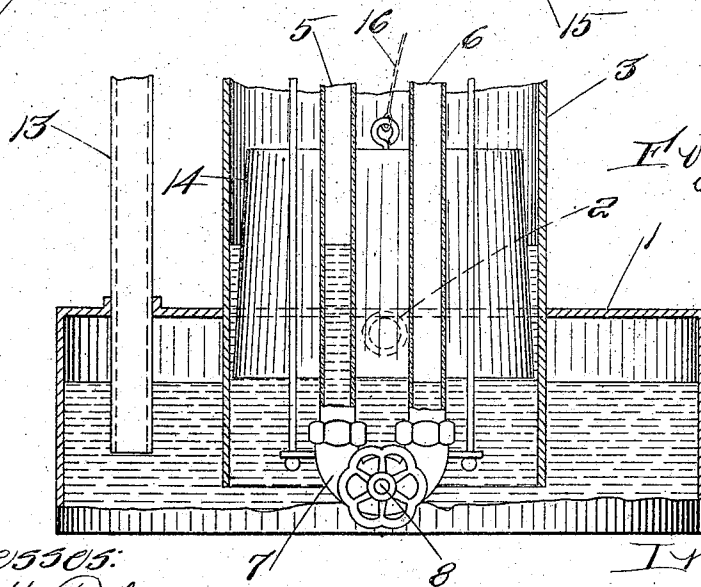

Fig. 4.

Witnesses:  
 John H. Parker  
 Aline Farr

Inventor:  
 Bartholomew R. Doody  
 by Macleod, Calver, Copeland & Dike  
 Attorneys.

# UNITED STATES PATENT OFFICE.

BARTHOLOMEW R. DOODY, OF CANTON, MASSACHUSETTS.

LOW-PRESSURE STEAM AND ANALOGOUS SYSTEM.

No. 930,650.

Specification of Letters Patent. Patented Aug. 10, 1909.

Application filed January 14, 1909. Serial No. 472,218.

To all whom it may concern:

Be it known that I, BARTHOLOMEW R. DOODY, citizen of the United States, residing at Canton, in the county of Norfolk and State of Massachusetts, have invented a certain new and useful Improvement in Low-Pressure Steam and Analogous Systems, of which the following is a specification, reference being had therein to the accompanying drawings.

The object of the invention is to provide a combined damper regulator, pressure gage, water gage and safety device.

In the drawings:—Figure 1 is an elevation of apparatus embodying my invention when there is no steam pressure. Fig. 2 is a plan view thereof partly broken away. Fig. 3 is a section on line 3—3 of Fig. 1. Fig. 4 is an elevational view similar to Fig. 1, partly broken away, showing the apparatus when under pressure.

Referring to the drawings,—1 represents a pressure chamber which is filled with water to the proper level, as indicated in Fig. 1. The steam space of the pressure chamber is connected with the steam space of the steam boiler by a pipe 2 which is pitched toward the boiler and serves both to introduce steam from the boiler and also to carry off any excess water in the pressure chamber which may have been caused by condensation of the steam. Connecting with the pressure chamber and opening into it from the top is an expansion chamber 3 which extends down into the pressure chamber to some distance below the normal level of the water line in the pressure chamber and nearly to the bottom of said chamber. The upper end of the expansion chamber extends some distance above the top of the pressure chamber. The expansion chamber is open to the atmosphere at the top.

Connected with the pressure chamber at the lower part thereof in any suitable way are two glass water gages 5, 6, which for convenience of connection are preferably connected with the pressure chamber by a fitting 7 provided with a valve 8 to open or shut off the connection between the pressure chamber and the water gages as desired. The upper ends of the water gages are preferably connected with the metal fitting 9 at their upper ends, the gage 5 being open to the atmosphere at its upper end as by a vent 10 and is shut off from connection with the other water gage 6 as by a partition 11. The gage 6 at its upper end is connected by a re-

turn tube 4 with the steam space of pressure chamber 1. Any suitable tubular connection between the upper end of the water gage 6 and the steam space of the pressure chamber may be used instead of the form of construction shown. Connected with the gage 6 at its upper end is a valve 12 for the purpose of shutting off the steam from said gage if necessary.

A relief pipe 13 is connected with the top of the pressure chamber and extends down into the pressure chamber considerably below the water level but preferably not quite so low as the expansion chamber. It preferably rises higher than the expansion chamber and the upper end preferably terminates in a goose-neck which extends over the top of the expansion chamber so that any water carried up through the pipe will fall into the expansion chamber.

Fitting loosely within the expansion chamber is a float 14 which is preferably formed slightly tapering upward, its lower end being of a little less diameter than the inside diameter of the expansion chamber, that is, so that the water can rise in the expansion chamber around the float. This float is preferably hollow made of tin, copper or other sheet metal, and is provided with a weighted metal ring 15 at its lower end on the inside of the periphery so that it will sink somewhat below the surface of the water and keep the float in a vertical position. Normally, that is, when there is no steam pressure in the pressure chamber and the water is at its normal level in the pressure chamber, the weight of the float will cause it to sink nearly to the bottom of the chamber. Connected with the upper end of the float is a chain or other flexible connection 16 which leads out of the upper end of the expansion chamber over suitable pulleys to the dampers, draft doors, etc. When there is no steam pressure, the water in both glass gages will stand at the same level as the water in the pressure chamber.

The operation is as follows: We will assume that the device has been filled with water to the proper level and that it has been connected to the steam space of a boiler by means of a pipe pitched toward the boiler and that a fire is started under the boiler. As the water heats and vapor arises therefrom, creating a pressure in the boiler, this pressure will through pipe 2 force the water downward in the pressure

chamber and upward in the expansion chamber through the connection between these two chambers at the bottom of the expansion chamber. As the water is thus forced upward in the expansion chamber, the float is lifted and by means of the flexible connection 16, closes the dampers, draft doors, etc., thus checking the fire. The fire thus checked, pressure in the boiler disappears, the water in the pressure chamber returns to normal level, the water and float in the expansion chamber descend. As the float descends, the dampers and draft doors are thereby opened, the fire is stimulated, again pressure is exerted as before and so the thing goes on, the dampers and draft doors being opened and closed, stimulating or checking the fire as the case may be. Should there be an excess of pressure at any time the water in the pressure chamber would continue to be depressed until it had reached to the lower end of the relief pipe when the pressure will be immediately relieved through said pipe which terminates in a goose-neck open to the atmosphere. Any water carried upward by the escaping vapor is returned to the device through the expansion chamber by means of the goose-neck. The gages operate as follows. At no pressure water stands at same level in both tubes. It will be seen that both gage tubes are connected at the bottom with the water in the pressure chamber, while at the top one of said tubes connects with the steam space of said chamber and the other tube is open to the atmosphere and does not have a steam connection at the top. When there is any pressure in the device, the water in the tube connected top and bottom with the pressure chamber will be depressed while the one connected with the water at the bottom and open to the atmosphere at the top will be elevated. Gage 5 will indicate the level of the water in the pressure chamber while gage 6 will indicate the level of the water in the expansion chamber. The difference in the level of the water indicates the pressure in the system. The apparatus once filled will remain so as the condensation of vapor will furnish a constant supply while any surplus will be carried off through the connection to the boiler. The pressure pipe must pitch from the pressure chamber toward the boiler and enter the pressure chamber at a height necessary to maintain the water line at such a level in relation to the lower end of the relief pipe and also the lower end of the expansion chamber as to seal the lower end of the relief pipe and expansion chamber up to a predetermined pressure.

Once in operation, the apparatus is absolutely automatic, controlling dampers, indicating water level as well as pressure, maintaining the necessary water level and relieving all undue pressure.

While I have especially described the invention as adapted to use in connection with a steam boiler, it is also adapted for use in connection with a hot water boiler and it is intended that the claims shall be construed to cover both a steam and a hot water system.

I claim as my invention:

1. In combination with a boiler, a pressure chamber containing water at a normal level below the inlet from the steam chamber of the boiler, a pipe leading from said steam chamber into the pressure chamber above the water line, an expansion chamber whose lower end opens into the pressure chamber below the normal level of the water in the pressure chamber, the upper end of the expansion chamber extending above the top of the pressure chamber and being open to the atmosphere, and a float fitting loosely within said expansion chamber, said float having a connection with a damper.
2. In combination with a boiler, a pressure chamber, two water gages both opening into the pressure chamber at their lower ends below the normal water line in the pressure chamber, one of said gages having at its upper end an opening to the atmosphere, the other of said gages being closed to the atmosphere and having a connection through which the steam pressure from the boiler is conducted into the upper part of said second gage, an expansion chamber whose upper end is open to the atmosphere and whose lower end is open to the pressure chamber below the normal water line in the pressure chamber, a float fitting loosely within said expansion chamber and a connection connecting the float with a damper.
3. In combination with a boiler, a pressure chamber, two water gages both opening into the pressure chamber at their lower ends below the normal water line in the pressure chamber, one of said gages having at its upper end an opening to the atmosphere, the other of said gages being closed to the atmosphere and having a connection through which the steam pressure from the boiler is conducted into the upper part of said second gage, an expansion chamber whose upper end is open to the atmosphere and whose lower end is open to the pressure chamber below the normal water line in the pressure chamber, a float fitting loosely within said expansion chamber, a connection connecting the float with a damper, and a relief pipe whose lower end extends down into the pressure chamber a less distance than the lower end of the expansion chamber but below the normal level of the water line and whose upper end is open to the atmosphere.
4. In combination with a boiler, a pressure chamber, a pipe connection leading from the steam chamber of the boiler into the steam space of the pressure chamber above the water line, an expansion chamber which

leads out of the pressure chamber and is open to the atmosphere, the lower end of the expansion chamber extending down below the normal water line in the pressure chamber; a relief pipe outside of the expansion chamber whose lower end also extends down into the pressure chamber below the normal level of the water line but less distance than the lower end of the expansion chamber and whose upper end is open to the atmosphere, and a float fitting loosely within said expansion chamber and a flexible connection extending from said float outside of the expansion chamber and adapted to be connected with a damper.

5. In combination with a boiler, a pressure chamber, a pipe connection leading from the steam chamber of the boiler into the steam space of the pressure chamber above the water line, an expansion chamber which leads out of the pressure chamber and is open to the atmosphere, the lower end of the expansion chamber extending down below the normal water line in the pressure chamber, a relief pipe outside of the expansion chamber, whose lower end also extends down into the pressure chamber below the normal level of the water line and whose upper end is open to the atmosphere, and a float fitting loosely within said expansion chamber said float having a connection with a damper.

6. In combination with a boiler, a pressure chamber, a pipe connection leading from the steam chamber of the boiler into the steam space of the pressure chamber, an expansion chamber which leads out of the pressure chamber and is open to the atmosphere at its upper end, the lower end of the expansion chamber extending down below the normal water line, a relief pipe outside of the expansion chamber whose lower end also extends down into the pressure chamber below the normal level of the water line and whose upper end is open to the atmosphere, and a float fitting loosely within said expansion chamber, said float being hollow and provided with a weight around the inside of its periphery and near the lower end of the float and a flexible connection extending out of the expansion chamber and adapted to be connected with a damper.

7. In combination with a boiler, a pressure chamber, a pipe connection leading from the steam chamber of the boiler into the pressure chamber above the water line, an expansion chamber which leads out of the pressure chamber and whose lower end extends down below the normal level of the water in the pressure chamber, the upper end of the expansion chamber extending some distance above the top of the pressure chamber and being open to the atmosphere, a relief pipe whose lower end also extends down into the pressure chamber below the normal level of the water line and whose upper end is open

to the atmosphere, and a float fitting loosely within said expansion chamber, said float having a flexible connection at its upper end extending out of the expansion chamber and adapted to be connected with a damper.

8. In combination with a boiler, a pressure chamber, a pipe connection leading from the steam chamber of the boiler into the steam space of the pressure chamber, two water gages both opening into the pressure chamber at their lower ends below the water line in the chamber, one of said gages having at its upper end an opening to the atmosphere, and the other of said gages being closed to the atmosphere and having at its upper end a return tubular connection opening into the steam space of the pressure chamber, an expansion chamber which surmounts the pressure chamber and whose lower end extends down into the pressure chamber below the normal water line in the pressure chamber, the lower end of the expansion chamber being open to the pressure chamber and the upper end of the expansion chamber being open to the atmosphere, a float in the lower end of the expansion chamber, and a connection leading from the float to a damper.

9. In combination with a boiler, a pressure chamber, two water gages both opening into the pressure chamber at their lower ends below the normal water line in the pressure chamber, one of said gages having at its upper end an opening to the atmosphere, the other of said gage being closed to the atmosphere and having a connection through which the steam pressure from the boiler is conducted into the upper part of said second gage, an expansion chamber whose upper end is open to the atmosphere and whose lower end is open to the pressure chamber below the normal water line in the pressure chamber, a float fitting loosely within said expansion chamber and a connection connecting the float with a damper.

10. In combination with a boiler, a pressure chamber, a pipe connection leading from the steam chamber of the boiler into the steam space of the pressure chamber, two water gages both opening into the pressure chamber at their lower ends below the normal water line in the pressure chamber one of said gages having at its upper end an opening to the atmosphere, and the other of said gages being closed to the atmosphere and having at its upper end a return tubular connection opening into the steam space of the pressure chamber, an expansion chamber which surmounts the pressure chamber and whose upper end is open to the atmosphere and whose lower end extends down into the pressure chamber below the normal water line in the pressure chamber and is open at its lower end, and a pipe mounted in the top of the pressure chamber outside of the expansion chamber, the lower end of the pipe

70

75

80

85

90

95

100

105

110

115

120

125

130

- extending down into the pressure chamber a less distance than the lower end of the expansion chamber but below the normal level of the water line and whose upper end is open to the atmosphere, a float fitting loosely within said expansion chamber and a connection connecting the float with a damper.
11. In combination with a boiler, a pressure chamber, a pipe connection leading from the steam chamber of the boiler into the steam space of the pressure chamber, two water gages both opening into the pressure chamber at their lower ends below the water line in the pressure chamber, one of said gages having at its upper end an opening to the atmosphere, and the other of said gages being closed to the atmosphere and having at its upper end a return tubular connection opening into the steam space of the pressure chamber, an expansion chamber which surmounts the pressure chamber and whose upper end is open to the atmosphere and whose lower end extends down into the pressure chamber below the normal water line in the pressure chamber and is open at its lower end, and a pipe mounted in the top of the pressure chamber outside of the expansion chamber, the lower end of the pipe extending down into the pressure chamber a less distance than the lower end of the expansion chamber but below the normal level of the water line and whose upper end is open to the atmosphere, and a float fitting loosely within said expansion chamber, said float having a flexible connection at its upper end which extends out of the expansion chamber and is adapted to be connected with a damper.
12. In combination with a boiler, a pressure chamber, a pipe connection leading from the steam chamber of the boiler into the steam space of the pressure chamber, two water gages both opening into the pressure chamber at their lower ends below the water line in the pressure chamber, both of said gages extending some distance higher than the water line of the pressure chamber, one of said gages having at its upper end an opening to the atmosphere and the other of said gages being closed to the atmosphere and having at its upper end a return tubular connection opening into the steam space of the pressure chamber, an expansion chamber which surmounts the pressure chamber and whose upper end is open to the atmosphere and whose lower end extends down into the pressure chamber below the normal water line in the pressure chamber and is open at its lower end, and a pipe mounted in the top of the pressure chamber outside of the expansion chamber, the lower end of the pipe extending down into the pressure chamber a less distance than the lower end of the expansion chamber but below the normal level of the water line and whose upper end is open to the atmosphere, and a hollow float fitting loosely within said expansion chamber, said float having an annular weight around the inside of its lower periphery and having a connection at its upper end which extends out of the expansion chamber and is adapted to be connected with a damper.
13. In combination with a boiler, a pressure chamber containing water at a normal level below the inlet from the steam chamber of the boiler, a pipe leading from said steam chamber into the pressure chamber above the water line, an expansion chamber whose lower end opens into the pressure chamber below the normal level of the water in the pressure chamber, the upper end of the expansion chamber extending above the top of the pressure chamber, means connected with the pressure chamber to indicate the pressure in the chamber and a float fitting loosely within said expansion chamber, said float having a connection with a damper.
14. In combination with a boiler, a pressure chamber, a pipe leading from the steam chamber of the boiler into the steam space of the pressure chamber, the pressure chamber containing water whose level is normally below the inlet from the steam chamber, an expansion chamber connected with the pressure chamber, a float fitting loosely within said expansion chamber, said float being provided with a weight around the inside of its periphery at its lower end and a flexible connection connecting the float with a damper.
15. In combination with a boiler, a pressure chamber containing water at a normal level below the inlet from the steam chamber of the boiler, a pipe leading from said steam chamber into the pressure chamber above the water line, an expansion chamber whose lower end opens into the pressure chamber below the normal level of the water in the pressure chamber, the upper end of the expansion chamber extending above the top of the pressure chamber and being open to the atmosphere, a water gage opening into the pressure chamber below the normal level of the water line and means connected therewith to indicate the pressure in the chamber.
- In testimony whereof I affix my signature, in presence of two witnesses.
- BARTHOLOMEW R. DOODY.
- Witnesses:  
WILLIAM A. COPELAND,  
ALICE H. MORRISON.